

**Steel case dry pressure gauges**, parts in contact with the process in brass material, sensing element Bourdon tube, suitable for applications with non aggressive fluids or gases to the copper alloy.

### P-Type local mounting, back connection

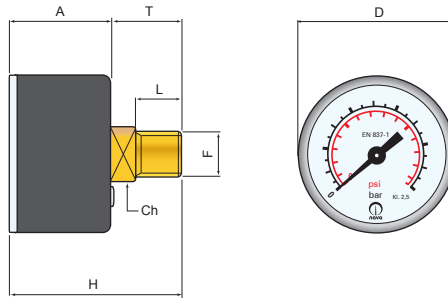

Dimensions: mm	A	C	D	d	F	H	I	K	L	M	T	Ch	Weight
P-Type	25		39		1/8 Gas / NPT - PG 7	40			10		15	12	

#### Technical features

**Reference standard:** EN 837-1.  
**Pressure ranges:** from -1 bar to 600 bar.  
**Accuracy:** Kl. 2,5 % according to EN 837-1.  
**Ambient temperature:** -25 ...+65 °C.  
**Process fluid temperature:** +0 ...+65 °C.  
**Thermal effect:** When working temperature deviates from reference temperature (+ 20°C): max ± 0,4 % / 10K of end-of-scale value.  
**Working pressure:** Steady: 3/4 full scale value.  
 Fluctuating: 2/3 full scale value.  
 Short time: full scale value.  
**Ingress protection:** IP 40 according to EN 60 529 / IEC 529.

#### Design features

**Process connection:** Cu alloy.  
**Cu alloy Bourdon tube:** C-type < 60 bar;  
 helical-type ≥ 60 bar.  
**Case:** black painted steel.  
**Window:** plastic material SAN.  
**Movement:** Cu alloy.  
**Dial:** aluminium white with standard black / red lettering.  
**Pointer:** plastic material PA 66 30%GF.

#### Options

Threads on request obtainable from Ø12.  
 1/8 NPT nickel-plated process connection.  
 Internal pressure restrictor.  
 Damping treatment.  
 Average working temperature increased till 100 °C with special soft soldering.

#### Ordering Informations:

Type / Nominal Diameter / Pressure Range / Connection Type / Options

Modifications may take place and materials specified may be replaced by others without prior notice.  
 Specifications and dimensions given in this leaflet represent the state of engineering at the time of printing.

**Zinc-plated steel case dry pressure gauges**, parts in contact with the process in brass material, sensing element Bourdon tube, suitable for applications with non aggressive fluids or gases to the copper alloy.

### S-Type panel mounting with clamp, back connection

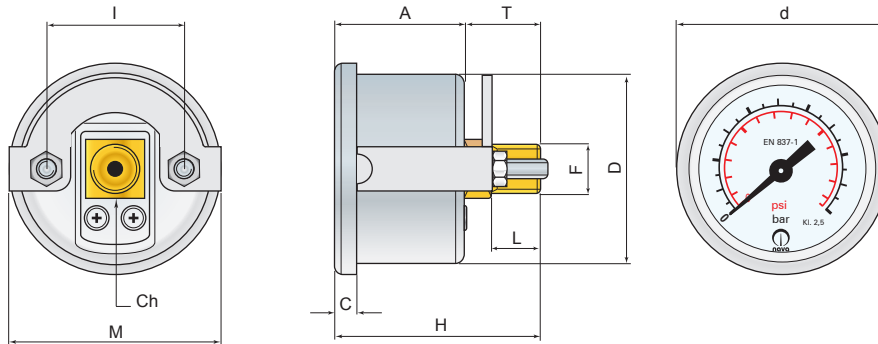

Dimensions: mm	A	C	D	d	F	H	I	K	L	M	T	Ch	Weight
S-Type	27	6	39	44	1/8 Gas / NPT - PG 7	42	27,5		10	44	15	12	

#### Technical features

**Reference standard:** EN 837-1.

**Pressure ranges:** from -1 bar to 600 bar.

**Accuracy:** Kl. 2,5 % according to EN 837-1.

**Ambient temperature:** -25 ...+65 °C.

**Process fluid temperature:** +0 ...+65 °C.

**Thermal effect:** When working temperature deviates from reference temperature (+ 20°C): max  $\pm 0,4 \%$  / 10K of end-of-scale value.

**Working pressure:** Steady: 3/4 full scale value.  
Fluctuating: 2/3 full scale value.  
Short time: full scale value.

**Ingress protection:** IP 65 according to EN 60 529 / IEC 529.

#### Design features

**Process connection:** Cu alloy.

**Cu alloy Bourdon tube:** C-type < 60 bar;  
helical-type  $\geq 60$  bar.

**Bezel ring:** stainless steel AISI 304.

**Case / Clamp:** zinc-plated steel.

**Window:** plastic material SAN.

**Movement:** Cu alloy.

**Dial:** aluminium white with standard black / red lettering.

**Pointer:** plastic material PA 66 30%GF.

#### Options

Mineral safety glass window.

1/8 NPT nickel-plated process connection.

Threads on request obtainable from  $\varnothing 12$ .

Average working temperature increased till 100 °C with special soft soldering.

Internal pressure restrictor.

Damping treatment.

#### Ordering Informations:

Type / Nominal Diameter / Pressure Range / Connection Type / Options

Modifications may take place and materials specified may be replaced by others without prior notice.  
Specifications and dimensions given in this leaflet represent the state of engineering at the time of printing.